

SPECIFICATION

Wattage:	Various
Supply voltage:	220-240V 50/60Hz
Ingress protection IP:	IP65
Impact protection IK:	IK05
Colour temperature:	3000K/ 4000K
Driver:	Tridonic
Chip:	Samsung
Power factor:	>0.95
Lifetime @ L80B50:	75 000hrs
Diffuser:	tempered glass, silicon gasket
Reflector:	faceted aluminum, 50° light beam, UGR<19
Weight:	1200g



DESCRIPTION

A recessed LED downlight with faceted reflector ideal for environments subject to humidity and excessive dust.

Glare-free light distribution 19 (UGR<19). LG05:Lighting for education and LG07:Lighting for offices compliant.

IP65 LED Downlight complete with remote IP65 LED Driver

IES/LDT files available on request.

PHOTOMETRIC

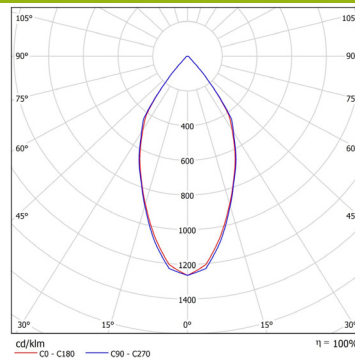

FURTHER INFORMATION

Mounting: Recessed

Body: Die-cast Aluminum
Colour: White

Available on request;
Dimming: Switch dimming, DALI
Emergency: 3hrs, DALI
RAL Colours

AVAILABLE OPTIONS

Rated power(W)	Lumens (lm)	Colour Temperature (K)	CRI	Luminaire Efficacy(lm/W)	Beam Angle	Dimensions L W Cutout (mm)
19.9	2251	4000	>80	113	50°	ø225 x 125 x 195
28.0	3074	4000	>80	110	50°	ø225 x 125 x 195
42.3	4426	4000	>80	105	50°	ø225 x 125 x 195

TECHNICAL DRAWINGS

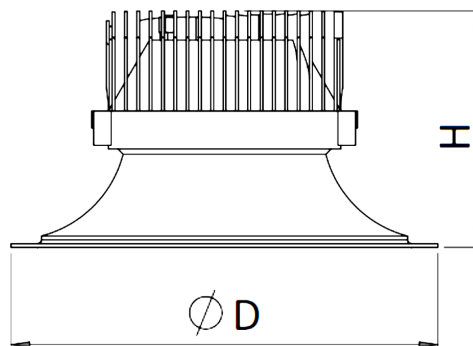

ø D, mm	H, mm	ø A, mm
225	125	195-210