

### SPECIFICATION

Wattage:	Various
Supply voltage:	220-240V 50/60Hz
Ingress protection IP:	IP65
Impact protection IK:	IK06
Colour temperature:	3000K/4000K/5000K
Driver:	Tridonic
Chip:	Samsung
Power factor:	>0.95
Lifetime @ L70:	50 000hrs
Diffuser:	Non-glare glass cover (DGL)
Weight:	3300g/3300g/5800g/5800g/5900g/ 10700g/11300g



### DESCRIPTION

The Allied Everest N is an energy saving LED High-bay Luminaire for high mounting applications and one-for-one replacement of 150W, 250W and 400W HID luminaires. With exceptional rated lifetimes, zero restrike time and significantly reduced lamp change maintenance costs.

IES/LDT files available on request.

### PHOTOMETRIC

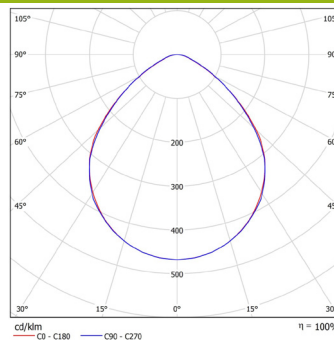

### FURTHER INFORMATION

Mounting: Suspended (Supplied with suspension hook)

Body: Die-cast Aluminium  
Colour: Dark grey

Available on request;  
Dimming: DALI, Switch-Control,

### AVAILABLE OPTIONS

Rated power(W)	Lumens (lm)	Colour Temperature (K)	CRI	Luminaire Efficacy(lm/W)	Beam Angle	Dimensions Dia H (mm)
34	4187	4000	>80	122	60°	ø358 x 231
51	5857	4000	>80	114	60°	ø358 x 231
84	9132	4000	>80	109	60°	ø459 x 301
107	11116	4000	>80	104	60°	ø459 x 301
131	13002	4000	>80	99	60°	ø459 x 301
154	17572	4000	>80	114	60°	ø561 x 361
180	19963	4000	>80	111	60°	ø561 x 361

### TECHNICAL DRAWINGS

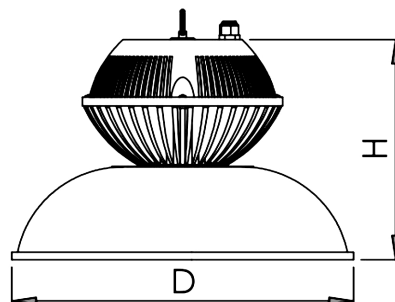

D, mm	H, mm
358	231
459	301
561	361